

REVISIONS			
REV.	DESCRIPTION	DATE	DRAWN

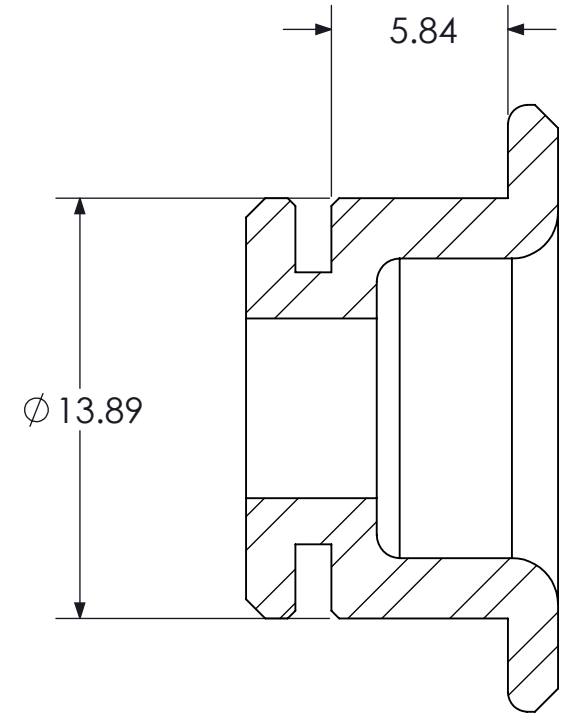

SECTION A-A

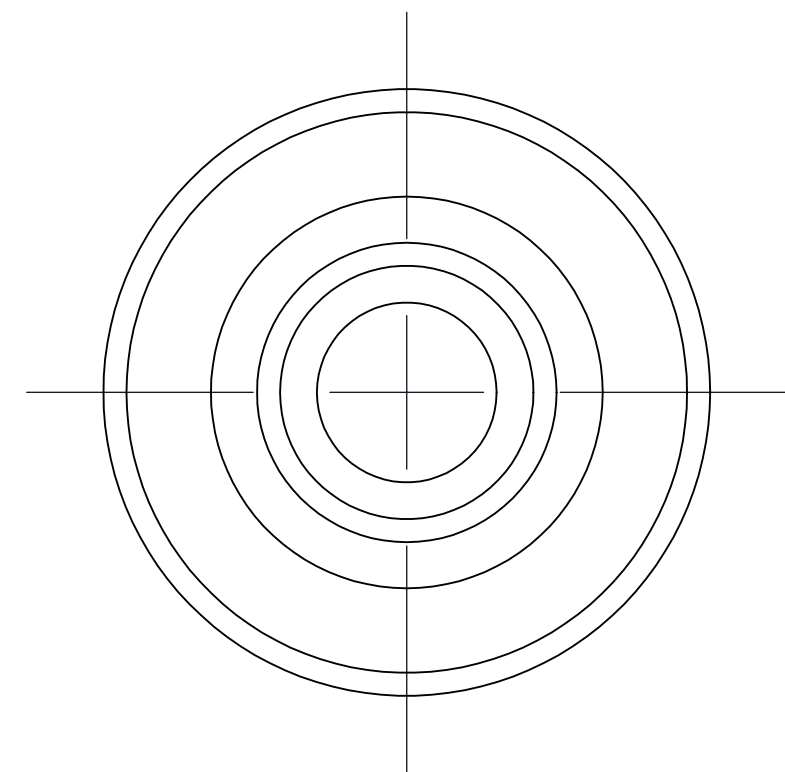
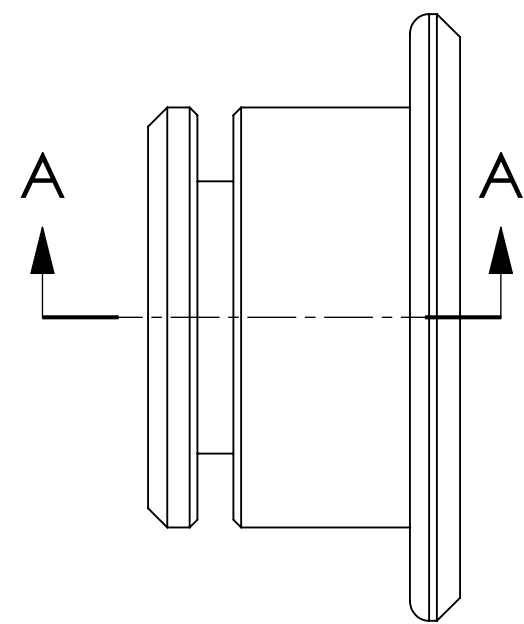
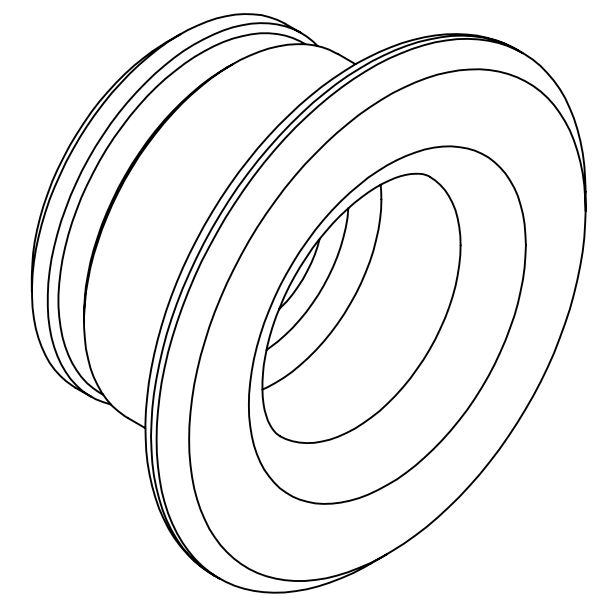

MATERIAL IS 7068 T6511
ANODIZE: HARD

PROPRIETARY AND CONFIDENTIAL
THE INFORMATION CONTAINED IN THIS
DRAWING IS THE SOLE PROPERTY OF
HASTINGS ENGINEERING INC.. ANY
REPRODUCTION IN PART OR AS A WHOLE
WITHOUT THE WRITTEN PERMISSION OF
HASTINGS ENGINEERING INC. IS
PROHIBITED.

	NAME	DATE		
DRAWN		XX/XX/XX		
CHECKED				
UNLESS OTHERWISE SPECIFIED:				
DIMENSIONS ARE IN INCHES TOLERANCES:			DESCRIPTION	
FRACTIONAL $\pm 1/32$ ANGULAR ± 1 2 DECIMAL $\pm .010$ 3 DECIMAL $\pm .005$ FORMED SHEETMETAL $\pm .030$			FLOATER BUTTON	
MATERIAL		SIZE	PART #	REV #
FINISH		B		
DO NOT SCALE DRAWING			SCALE: 4:1	SHEET 1 OF 1