

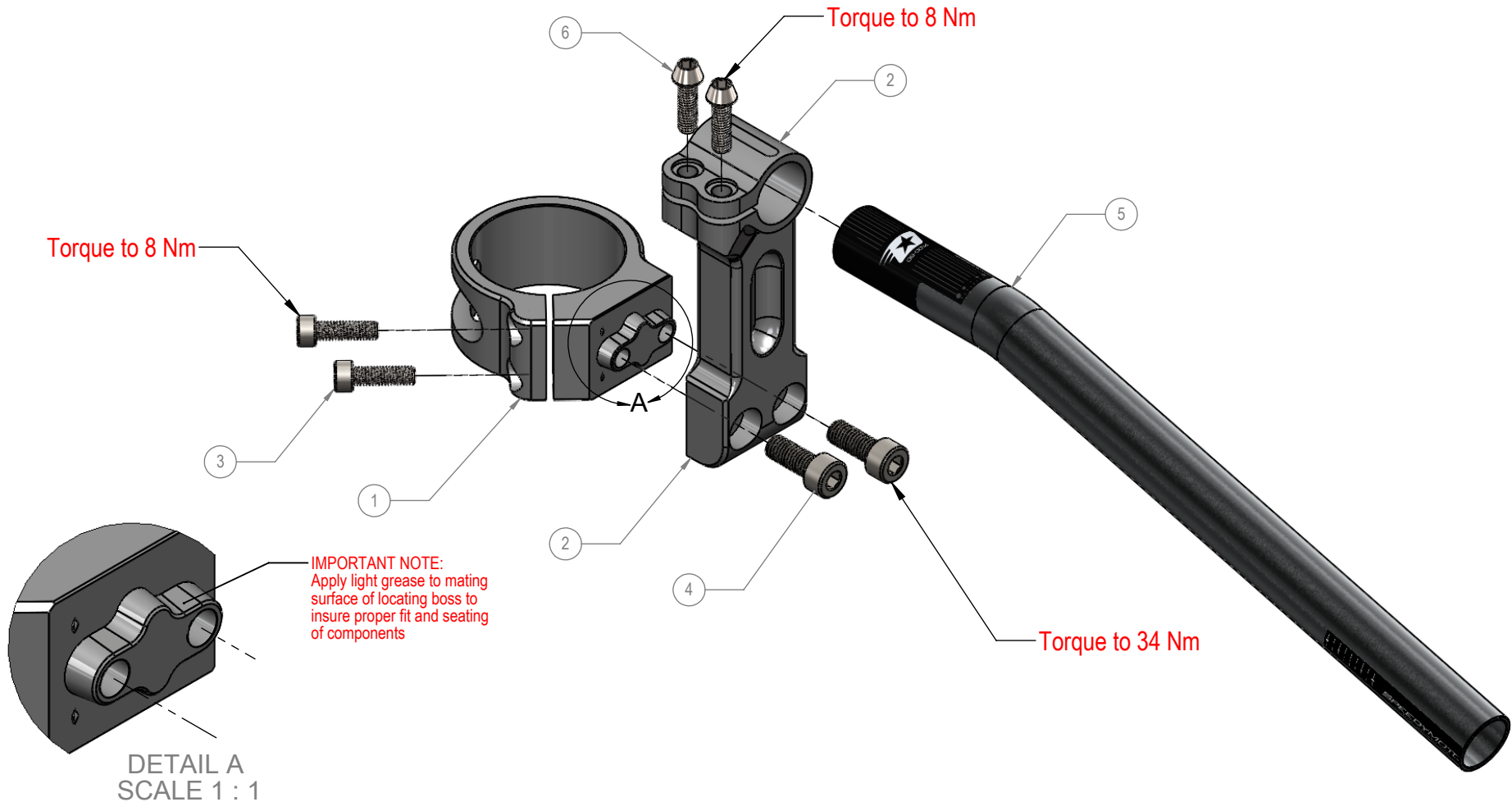

ITEM NO.	PART NUMBER	DESCRIPTION	QTY.
1	RP-08-0050 TB	50 mm Fork Clamp	1
2	RP-08-076R	76 mm Tall Boy Riser	1
3	M6 x 20 SS SHCS	M6 x 20mm Socket Head Cap Screw	2
4	M8 x 20 SS SHCS	M8 x 20mm SS Socket Head Cap Screw	2
5	08-0014	Clip On Bar, 14 Degree	1
6	M6 x 18 SS Taper SHCS	M6 x 18mm Tapered Socket Head Cap Screw	2



08-07650

Complete Right Side Clip On

2/21/2013



## Installation instructions

Tall Boys

**Tools required** (good excuse to buy more tools)

1. Metric Hex tools 4mm, 5mm, 6mm (Sockets and T-handles)
2. Torque wrench (range between 8Nm – 35Nm)

## Installation

1. First note the position of the cables and wires then start to loosen controls, throttle, brake and clutch.
2. Remove left side grip.
3. Loosen triple clamp pinch bolts and carefully remove top triple clamp.
  - a) If your bike has clip-ons stock, loosen stock clip-on pinch bolts and remove stock clip-ons. Leave controls and levers on the stock clip-ons until you are ready to swap.
  - b) If your bike has handlebars stock, separate handlebar from triple clamp. Leave controls and levers on the stock clip-ons until you are ready to swap.
4. **IMPORTANT: apply grease or anti seize to the mating surface of locating boss between riser and clamp to ensure proper fit and seating of components!** See DETAIL A on the exploded view.
5. You can now install the Tall Boys onto the fork clamps and position. Apply a little blue Locktite to all hardware.
6. **Important:** Before moving on, torque the four large M8x20mm bolts that hold the risers to the fork clamps. Torque these bolts to 34 Newton meters.
7. Re-install top triple clamp and torque bolts to factory recommended specs.
8. For easy installation of the controls, we recommend clipping or filing off the locating pins from the controls and throttle housing.
9. Swap controls from old clip-ons to new Omni Bars and slide into the Tall Boys, keep everything loose.
10. You can now start to position everything.
  - a) Take your time and be patient.
  - b) It is nice to have a helping hand at this point.
  - c) Check clearance often and don't be afraid to re-adjust.
  - d) You may need to change the cable and wire routing.
  - e) You may need to adjust steering stops.
11. When you are satisfied with the position, tighten everything down and set torque to the recommended settings. See exploded view for Tall Boys torque settings.
12. **Ride it and tell all of your friends about SpeedyMoto!!!**

*SPEEDYMOTO*  
13339 NE AIRPORT WAY, SUITE 400  
PORTLAND OR 97230